



Department of Public Works
Engineering Division
James M. Wolfe, P.E., City Engineer

City-County Building, Room 115
210 Martin Luther King, Jr. Boulevard
Madison, Wisconsin 53703
Phone: (608) 266-4751
Fax: (608) 264-9275
engineering@cityofmadison.com
www.cityofmadison.com/engineering

Assistant City Engineer
Bryan Cooper, AIA
Gregory T. Fries, P.E.
Chris Petykowski, P.E.
Deputy Division Manager
Kathleen M. Cryan
Principal Engineer 2
John S. Fahrney, P.E.
Janet Schmidt, P.E.
Principal Engineer 1
Mark D. Moder, P.E.
Financial Manager
Steven B. Danner-Rivers

January 25, 2023

**NOTICE OF ADDENDUM
ADDENDUM 1
CONTRACT NO. 9280
FIRE STATION 10 LIGHTING RETROFIT**

Revise and amend the contract document(s) for the above project as stated in this addendum, otherwise, the original document shall remain in effect.

Please acknowledge this addendum on page E1 of the contract documents and/or in Section E: Bidder's Acknowledgement on Bid Express.

Electronic version of these documents can be found on the Bid Express web site at:
<http://www.bidexpress.com>

If you are unable to download plan revisions associated with the addendum, please contact the Engineering office at 608-266-4751 receive the material by another route.

- 1 Replace sheet EL 200 with a new sheet EL 200
 - A Use 3' strip light instead of 4' strip light to clear existing pipe in space 102. Added clarification for location of fixture.
 - B Add note clarifying what to do with loudspeakers and other devices in Space 001.
- 2 Replace sheet EL 300 with a new sheet EL 300
 - a Updated fixture schedule to reflect change of fixture on sheet EL 200 (s. above)

Sincerely,

Bryan Cooper for:

James M. Wolfe, P.E., City Engineer

JMW:ks

Revisions	
No.	Description
1	Addendum 01

Project North
TRUE

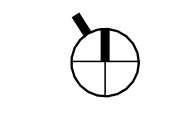

Lighting

EL 200

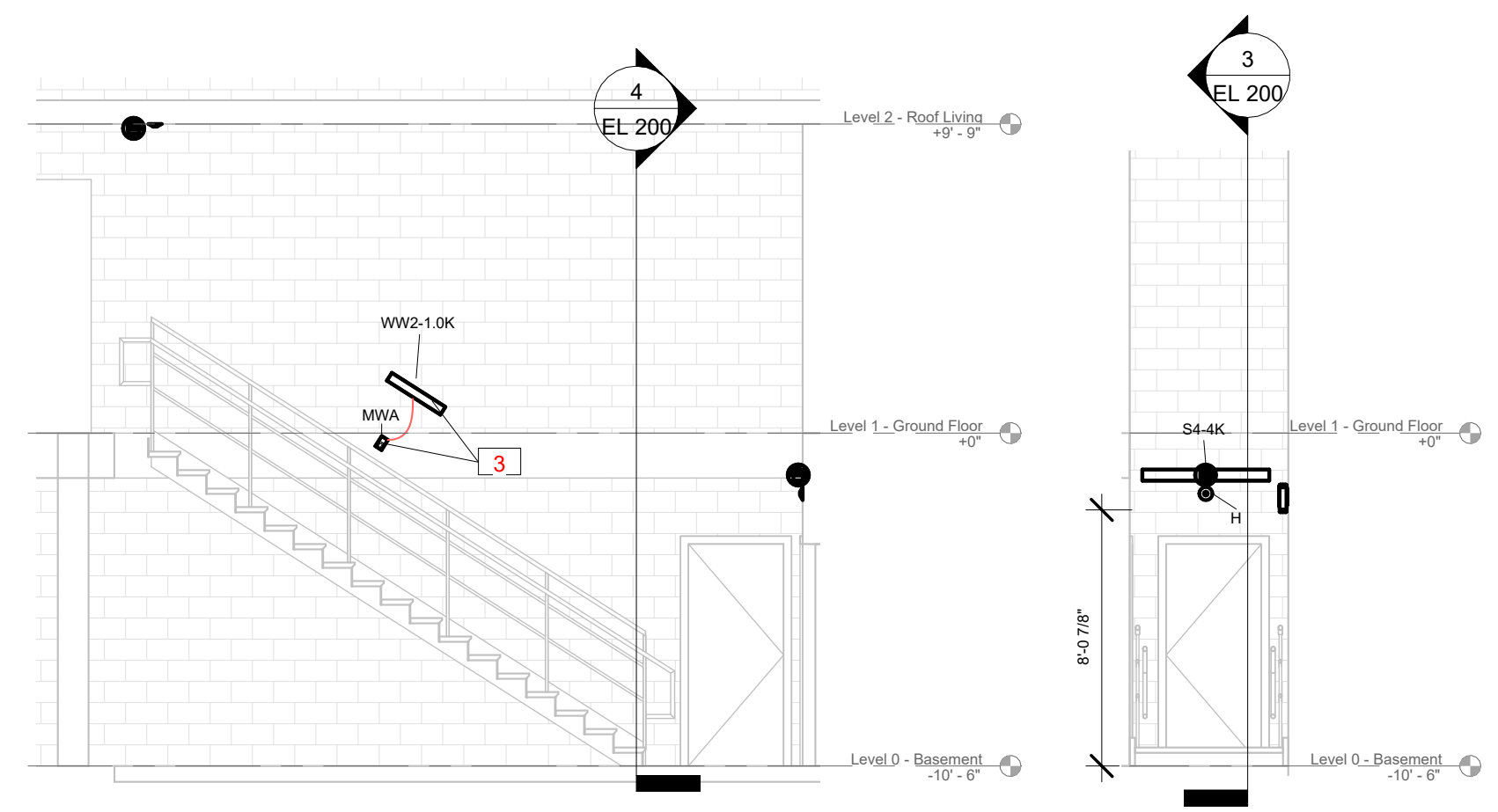

3 EL Section - Stairs 3/16" = 1'-0"

4 EL Section - Stair Face Wall 3/16" = 1'-0"

Key Value	Keynote Text
1	Motion sensor upstream of switch. Don't wire sensor dimmer. All dimming by manual dimmer only.
2	Use Existing Switch
3	Rotate wall-sensor and light fixture to be parallel to stair-slope. Optimize detection of people coming from up- and downstairs. Review sensor coverage pattern.
4	Disable switching. Dimming function only.
5	Power all emergency lighting fixtures and exit signs from this battery power inverter.
6	XTO Fire Alarm Panel. Wire from here to the UL S24 relays in the spaces.
7	Install switch in office compartment of furniture: not conduit similar to existing conduit (on top of cabinet) to wall.
8	Install spotlight with asymmetric light distribution aimed towards map.

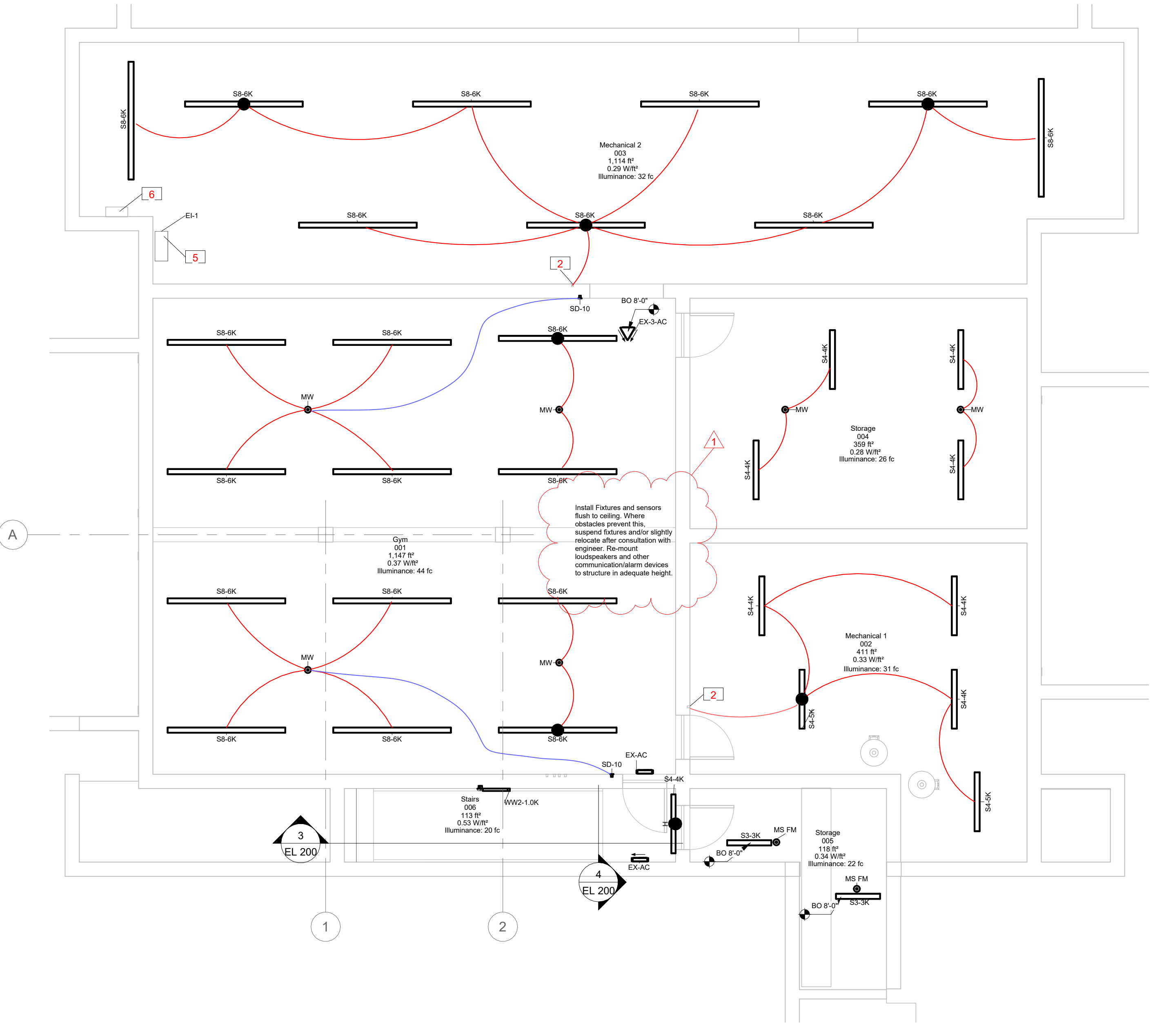

1 EL Ceiling - Level 0 3/16" = 1'-0"

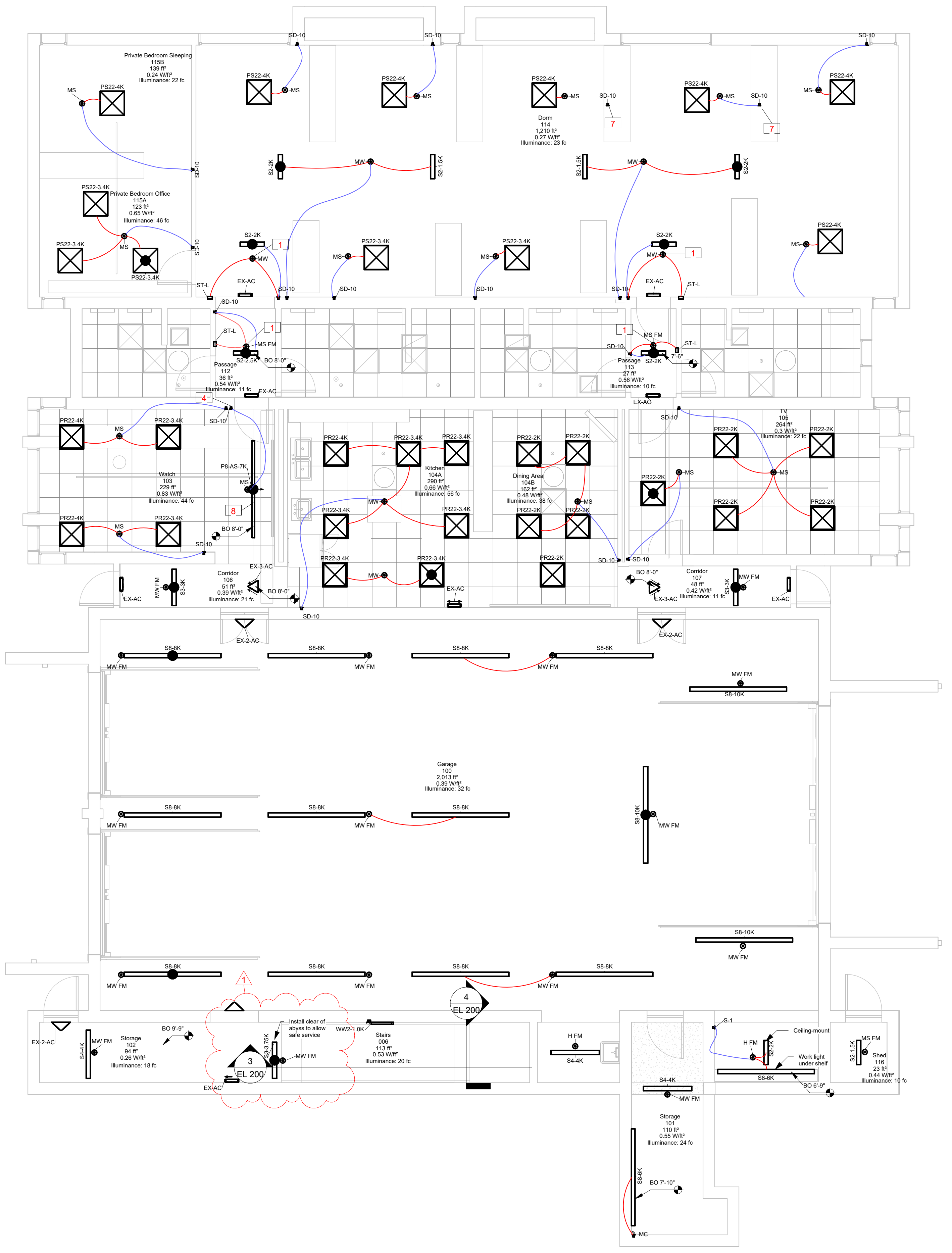

2 EL Ceiling - Level 1 3/16" = 1'-0"

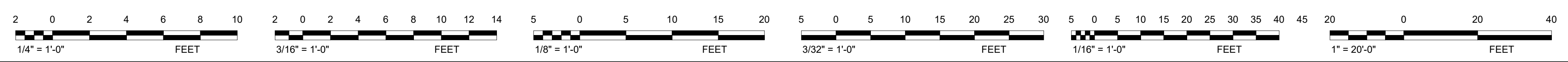

Lighting Device Schedule						
Type Mark	Description	Est. Count	Model	URL	Type Remark	Specification
H	Motion Sensor High Bay	1	Sensorswitch CMR-6-D-P-VLP	www.acuitybrands.com	26 09 23 - Lighting Control Devices	
H FM	Motion Sensor High-Bay, Fixture-mount	2	Sensorswitch LXR-6-ADC-VLP	www.acuitybrands.com	26 09 23 - Lighting Control Devices	
MC	Motion Sensor Corner-mount w/ powerpack	1	Sensorswitch WY-6-R-4-CT-PP20	www.acuitybrands.com	26 09 23 - Lighting Control Devices	
MS	Motion Sensor short Range	16	Sensorswitch CMR-9-PDT-ADC-VLP	www.acuitybrands.com	26 09 23 - Lighting Control Devices	
MS FM	Motion Sensor short Range, Fixture-mount	5	Sensorswitch LXR-9-ADC-VLP	www.acuitybrands.com	26 09 23 - Lighting Control Devices	
MW	Motion Sensor wide Range	12	Sensorswitch CMR-10-PDT-ADC-VLP	www.acuitybrands.com	26 09 23 - Lighting Control Devices	
MW FM	Motion Sensor wide Range, Fixture-mount	16	Sensorswitch LXR-10-ADC-VLP	www.acuitybrands.com	26 09 23 - Lighting Control Devices	
MWA	Motion Sensor Wall-mount 100' Coverage, 48" height	1	Sensorswitch LWS-WH	www.acuitybrands.com	26 09 23 - Lighting Control Devices	
S-1	Single Switch	7			26 09 23 - Lighting Control Devices	
SD-10	Switch w/ 0-10V Dimmer	24	Wattstopper RH4FBL3PW	www.legrand.us	26 09 23 - Lighting Control Devices	

Emergency Power Battery Inverters										
Mark	Space Number	Space Name	Description	Manufacturer	Model	URL	Output Rating @ 90 Minutes	In / Out Voltage	Weight	Remark
EI-1	003	Mechanical 2	Emergency Lighting Battery Inverter	Myers	EM-2-S-B	www.myersps.com	1600 VA	120 V	405 lb	For floor mount: option -F. For wall-mount use option -W.

Lighting Fixture Schedule											
Type Mark	Description	Est. Count	Model	URL	Apparent Load	Luminous Flux	Color Temperature	Efficacy	Lumen Maintenance	Type Remark	Specification
EX-2-AC	Exit Sign Triangular - no Battery	4	Big Beam TRXL-ACLED-2-G-W	www.bigbeam.com	4 VA						26 50 00 - Lighting
EX-3-AC	Exit Sign Triangular - no Battery	3	Big Beam TRXL-ACLED-3-G-W	www.bigbeam.com	4 VA						26 50 00 - Lighting
EX-AC	Exit Sign - no Battery	10	Lithonia GMR-S-W-3-G-MVOLT	www.acuitybrandslighting.com	1 VA						26 50 00 - Lighting
PB-AS-7K	Suspended / Surface	1	Focal Point FSM2ALS-875LF-40K-1C-UNV-L11-WH-Blt	www.focalpointlights.com	72 VA	7000 lm	4000 K	97 lm/W	L90 @ 128K hours	Choose surface or suspension kit as required. Review plans and site for detail.	26 50 00 - Lighting
PR22-2K	Panel Recessed 2x2	10	Lithonia EPANL-2x2-2000LMHE-40K-80CRI-MINI-ZT-MVOLT	www.acuitybrands.com	16 VA	1972 lm	4000 K	126 lm/W	L91 @ 60K hours		26 50 00 - Lighting
PR22-3-4K	Panel Recessed 2x2	8	Lithonia EPANL-2x2-3400LMHE-40K-80CRI-MINI-ZT-MVOLT	www.acuitybrands.com	27 VA	3399 lm	4000 K	123 lm/W	L91 @ 60K hours		26 50 00 - Lighting
PR22-4K	Panel Recessed 2x2	3	Lithonia EPANL-2x2-4000LMHE-40K-80CRI-MINI-ZT-MVOLT	www.acuitybrands.com	33 VA	4117 lm	4000 K	125 lm/W	L91 @ 60K hours		26 50 00 - Lighting
PS22-3-4K	Panel Surface 2x2	5	Lithonia EPANL-2x2-3400LMHE-40K-80CRI-MINI-ZT-MVOLT-2x2SMKSH	www.acuitybrands.com	27 VA	3399 lm	4000 K	126 lm/W	L91 @ 60K hours		26 50 00 - Lighting
PS22-4K	Panel Surface 2x2	7	Lithonia EPANL-2x2-4000LMHE-40K-80CRI-MINI-ZT-MVOLT-2x2SMKSH	www.acuitybrands.com	33 VA	4117 lm	4000 K	125 lm/W	L91 @ 60K hours		26 50 00 - Lighting
S2-1.5K	Strip 2	3	Lithonia CLX-14-1500LMHE-FRDL-MVOLT-EZ1-40K-80CRI	www.acuitybrands.com	10 VA	1436 lm	4000 K	138 lm/W	L70 @ 100K hours		26 50 00 - Lighting
S2-2.5K	Strip 2	1	Lithonia CLX-14-2500LMHE-FRDL-MVOLT-EZ1-40K-80CRI	www.acuitybrands.com	17 VA	2508 lm	4000 K	144 lm/W	L70 @ 100K hours		26 50 00 - Lighting
S2-3K	Strip 2	6	Lithonia CLX-14-3000LMHE-FRDL-MVOLT-EZ1-40K-80CRI	www.acuitybrands.com	13 VA	1981 lm	4000 K	147 lm/W	L70 @ 100K hours		26 50 00 - Lighting
S3-3.75K	Strip 3	1	Lithonia CLX-18-3750LMHE-FRDL-MVOLT-EZ1-40K-80CRI	www.acuitybrands.com	25 VA	3845 lm	4000 K	153 lm/W	L70 @ 100K hours		26 50 00 - Lighting
S3-5K	Strip 3	4	Lithonia CLX-18-5000LMHE-FRDL-MVOLT-EZ1-40K-80CRI	www.acuitybrands.com	20 VA	3004 lm	4000 K	150 lm/W	L70 @ 100K hours		26 50 00 - Lighting
S4-4K	Strip 4	11	Lithonia CLX-18-4000LMHE-FRDL-MVOLT-EZ1-40K-80CRI	www.acuitybrands.com	25 VA	3868 lm	4000 K	156 lm/W	L70 @ 100K hours		26 50 00 - Lighting
S4-5K	Strip 4	2	Lithonia CLX-18-5000LMHE-FRDL-MVOLT-EZ1-40K-80CRI	www.acuitybrands.com	32 VA	4839 lm	4000 K	152 lm/W	L70 @ 100K hours		26 50 00 - Lighting
S6-6K	Strip 6	23	Lithonia CLX-18-6000LMHE-FRDL-MVOLT-EZ1-40K-80CRI	www.acuitybrands.com	36 VA	5597 lm	4000 K	160 lm/W	L70 @ 100K hours		26 50 00 - Lighting
S6-8K	Strip 8	11	Lithonia CLX-18-8000LMHE-FRDL-MVOLT-EZ1-40K-80CRI	www.acuitybrands.com	49 VA	7662 lm	4000 K	157 lm/W	L70 @ 100K hours		26 50 00 - Lighting
S8-8K	Strip 8	3	Lithonia CLX-18-10000LMHE-FRDL-MVOLT-EZ1-40K-80CRI	www.acuitybrands.com	61 VA	8404 lm	4000 K	154 lm/W	L70 @ 100K hours		26 50 00 - Lighting
SFL	Strip Light w/ Lens, White	4	Control STRL-MA-LSP	www.contechlighting.com	2 VA	34 lm	1900 K	17 lm/W	50K hours		26 50 00 - Lighting
WW2-1.6K	Linear Wall-Wash LED Light Fixture	1	Focal Point FSM1W-AS-500-40K-1C-UNV-L11-WM-WH-28	www.focalpointlights.com	10 VA	1000 lm	4000 K	100 lm/W	L90 @ 115K hours		26 50 00 - Lighting

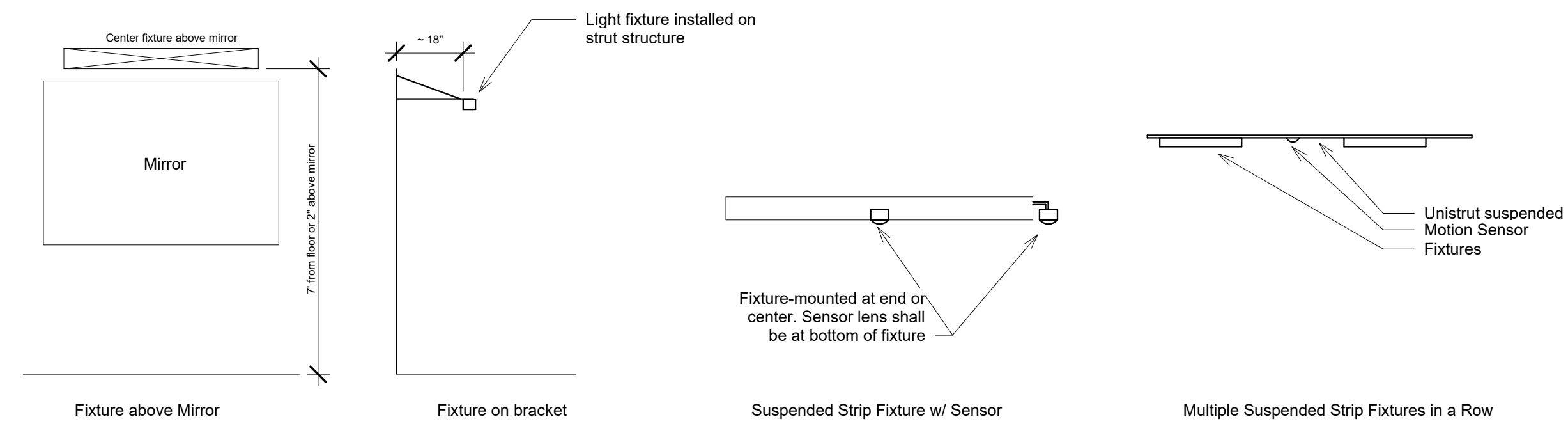

1 EL Typical Installation Details 1" = 1'-0"

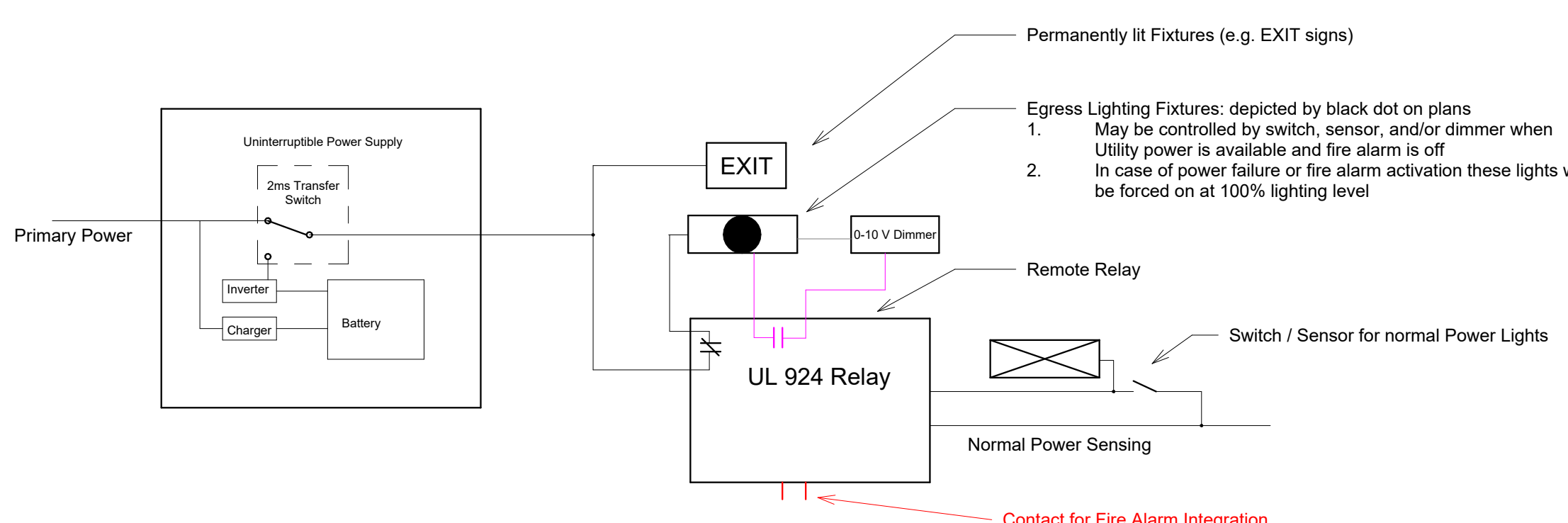

- Objective:**
- Emergency light fixtures (indicated by a black dot) and Exit signs will be powered by the Uninterruptible AC Power Supply (UPS). Wiring has to be extended from UPS to all devices.
 - When normal power is present and fire alarm is OFF, lighting will be controlled by lighting control system. Local switches, timers, dimmers and sensors control on/off and dimming.
 - When fire alarm is not present, the emergency fixtures and exit signs will be powered by the battery for over 90 minutes. These fixtures will be forced on at 100% (no dimming).
 - When fire alarm is active, all emergency light fixtures will be forced on at 100% (no dimming).
 - Contractor shall verify availability of contacts in fire alarm panel and add relay(s) if required.
 - Wiring shall meet NEC 700.10 requirements. This includes, but is not limited to:
 - Separate emergency raceway. Raceway shall be marked.
 - Any junctions shall be labeled "Warning - 2 power sources" or as required by code
 - Label indicates panel, circuit, and voltage
 - Conduit for emergency lighting shall be color-coded as specified in Division 26
 - When accessible installation of UL 924 relay is not possible (e.g. drywall, exterior), install the relay in near-by accessible location. Verify location with engineer.
 - fixtures with built-in sensor shall be re-wired for UL 924 relay to bypass sensor (e.g. exterior fixture with included photocell)
- Testing:**
- Test by applying emergency power and normal power. Turn off local switch and set local dimmer to lowest dimming level.
 - If no local switch is available, disconnect the appropriate wire to simulate light being turned off.
 - If no local dimmer is available and dimming by sensor is scheduled, program sensor to dim to low level.
 - Disconnect normal sensing power and verify emergency light turns on to 100%
 - Re-instate normal power and activate fire alarm and verify emergency light turns on to 100%

2 EL Egress Lighting Control w/ UPS and Fire Alarm Integration 1" = 1'-0"

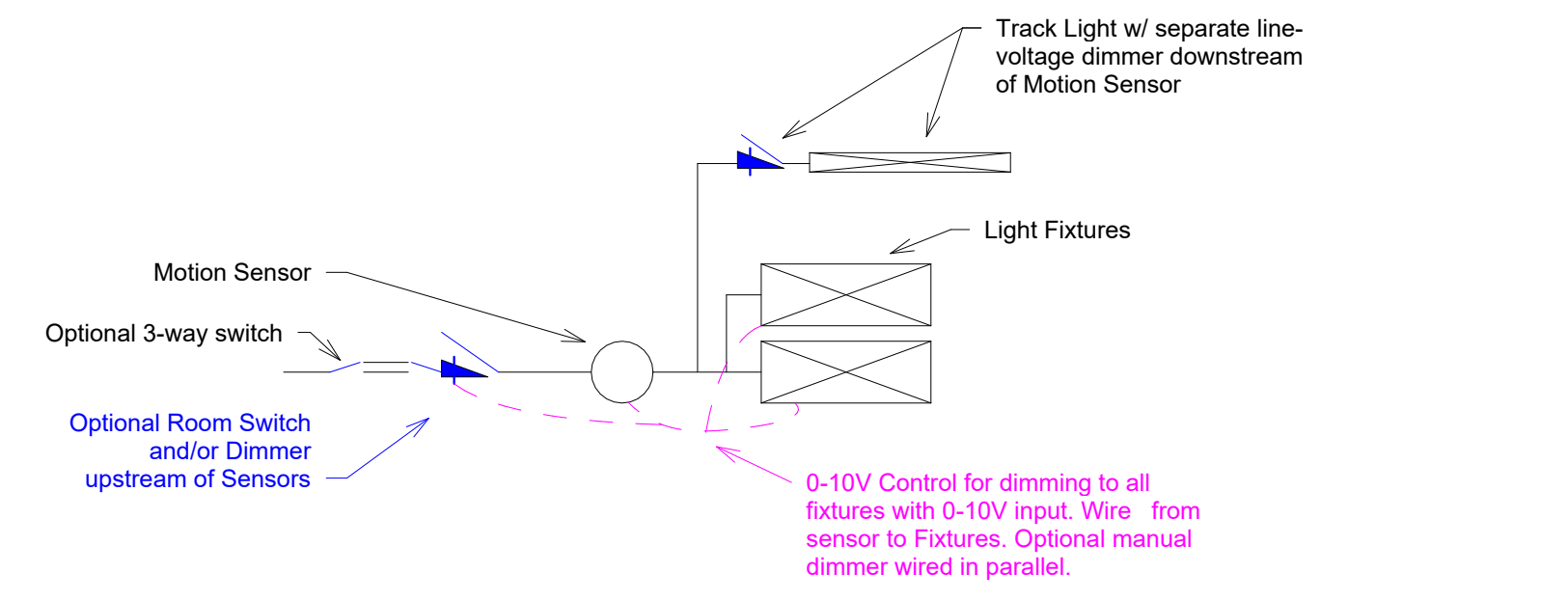

- Lighting zones with lighting-devices and light-fixtures are indicated by wire lines and/or switch leg (SL) numbers.
- Where devices allow, dimming shall be accomplished by 0-10V wiring of all devices.
- Where shown on plans, a zone may have 3-way and 4-way switches. Enable 3-way function on dimmer switch and wire appropriately to enable control from all switch locations. Fixtures and devices in the same above zone are denoted by the same switchleg (SL) number.
- Motion sensor with local switch will be de-energized when switch is off (sensor downstream of switch):
 - Light will be on upon activation of local switch regardless of actual motion detection (sensor is ON upon power-up)
 - Sensors will not click when local switch is off (nuisance avoidance in quiet rooms)
- Line-voltage dimmers (i.e. track lighting) shall be downstream of local motion sensor.
- Notes on plans or switchleg naming will indicate exceptions. For example:
 - Disable Switchleg: A dimmer will only dim the lighting level to the allowable minimum. The line voltage switch in the dimmer will not be used. This prevents lights turning off entirely. Hallways are an example.
 - One light fixture shall be controlled by switch only. Switchleg parameters indicate that some lights are controlled by switch and sensor, and some lights by switch only. This prevents the latter lights from turning off upon loss of motion detection. Electrical or mechanical rooms are examples.
- Sensor Programming Instructions:
 - The below is based on Sensorswitch Instructions at the time of design. Amend if different sensors are used or if manufacturer changes procedure. Confirm any deviation with engineer. Sensorswitch support#: 1-800-535-2465
 - If sensors are equipped with VLC programming option, a smartphone app shall be used. Note that sensors needs to be initialized and set with a PIN within 45 minutes of powering up. Program is sent to sensor via flashlight. Lights will blink to acknowledge successful programming.
 - Verify settings with engineer prior programming. Certain settings may be different in certain zones.
 - Sensors shall be programmed depending on availability of daylight. Save presets to avoid deviations.
 - No daylight available:
 - Enable "Time Delay" - Set to 15 minutes
 - Disable Trim
 - Enable "Dim to Off Delay" - set to 5 minutes
 - Disable Photocell
 - Daylight available (inc. spaces with overhead doors, skylights, windows within 20' of sensor)
 - Enable "Photocell" and set to "On/Off and Auto Dimming"
 - Enable "Auto Set Point"
 - After programming, all functions shall be tested to verify desired function. Adjust as required for intended function. Discuss problems with engineer.

3 EL Lighting Control Zone 1" = 1'-0"

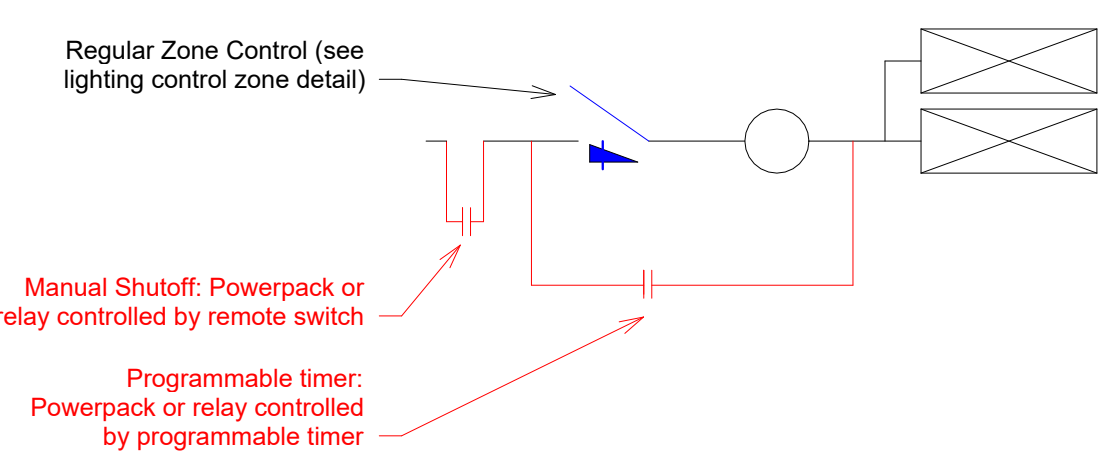

- Local Lighting Control Override**
- Plan will indicate which zones will be overridden.
 - Manual shut-off:
 - Staff can remotely turn off selected zones regardless of local lighting control, the remote switch is shown on plans (typically in a non-public location)
 - Programmable timer:
 - A central timer forces lights in zone on regardless of local control setting
 - Wiring from programmable timer and remote switch can be accomplished in line-voltage wiring or with low-voltage wiring and power-pack near lighting zone.

4 EL Local Lighting Control Overrides 1" = 1'-0"



Turn off lights when leaving room empty.

- Some spaces don't employ automatic lighting control and use manual switches only. These include but are not limited to mechanical, electrical, or crawl spaces.
- In these spaces, adhere a sign to the exit door indicating that lights shall be shut off upon leaving the space.
- Above sign is an example and similar signs can be used upon approval.

5 EL Manual Lighting Control 1" = 1'-0"



Client:
Madison Fire Department

Fire Station 10
Lighting Retrofit

Location:
1517 Troy Drive
Madison, WI 53704

Contract: 9280
Project: 14246

Revisions	
No.	Description
1	Addendum 01

Details and
Schedules

EL 300